



Scaling new heights
in manufacturing

Organiser



Indian Machine Tool
Manufacturers' Association



International Machine Tool &
Manufacturing Technology Exhibition

Concurrent Shows



International Exhibition of Cutting Tools, Tooling Systems,
Machine Tool Accessories, Measuring & QC/CPI



International Exhibition of
Digital Manufacturing Technology

23 - 29 January 2025 · BIEC, Bengaluru

TRANSFORMING MANUFACTURING OPERATIONS

BFW's New Machines Garner Rave Reviews @ IMTEX 2025

Bharat Fritz Werner's (BFW) newly launched range of machines at IMTEX 2025 have received an overwhelming response. With the theme 'Precision with Productivity', the new launches demonstrate the brand's automation capabilities and include standard machines, multi-purpose machines, hybrid machines, and 5-axis machines.



Bharat Fritz Werner Ltd
www.bfwindia.com
Hall & Stall: 2/A-102

Source: Magic Wand Media

BFW is a pioneering name in machine tools, manufacturing solutions, and technological innovation. With over 65,000 installations in 18 countries, BFW operates in 15 countries through channel partners. Its sales and service network is available at 48 locations in India, with five tech centers and a network of dealerships. The company has excellent design and engineering capabilities and two state-of-the-art manufacturing plants. It provides solutions that cater to the performance, productivity, and reliability expectations of diverse industries, such as aerospace, automotive, die & mold, forging, valves, railways, and more.

BFW has continuously invested in R&D and launched the Dr. Kalam Center for Innovation in 2016 to create applied R&D for next-generation manufacturing technologies. The company has integrated m2nxt Solutions and BAMPL as its wholly-owned subsidiary companies, offering advanced manufacturing solutions encompassing Industrial IoT, data analytics, robotics, fixtures, hybrid machines, and precision component manufacturing solutions. BFW has further strengthened its global footprint with the launch of BFW Europe and BFW North America, establishing a strategic presence with its France and Delaware offices to drive innovation and growth in international markets.

Indian Machine Tool Industry Going Strong

The launch of BFW's new machines at IMTEX 2025 reinforces BFW's commitment to the machine tool manufacturing sector which continues to exhibit a positive growth trend. Ravi Raghavan, Managing Director, BFW, expressed optimism for India's growth trajectory and BFW's contribution to the 'Make in India' initiative, stating, "India should be a US\$ 30 trillion economy by 2047, our 100th year of independence. During this time, the manufacturing sector would contribute about 25 percent of the GDP. The machine tool industry will also see almost eight-fold growth. There will be challenges but the innova-

tions are taking place at a rapid pace, and we will have to be prepared for this change as individuals, society, and as a country."

BFW's New Launches at IMTEX 2025

OMEGA Series

BFW's cutting-edge CNC machining centers redefine precision, speed, and productivity. With high-speed performance, a compact design, and simultaneous 5-axis machining, they deliver unmatched efficiency and accuracy for the most demanding applications. This series is engineered to meet the



Source: BFW

» India should be a US\$ 30 trillion economy by 2047, our 100th year of independence. During this time, the manufacturing sector would contribute about 25 percent of the GDP. The machine tool industry will also see almost eight-fold growth. There will be challenges but the innovations are taking place at a rapid pace, and we will have to be prepared for this change as individuals, society, and as a country.«

Ravi Raghavan
Managing Director
Bharat Fritz Werner Ltd



Source: BFW

demands of industries requiring complex machining and high-performance capabilities. Two machines of this series were launched at IMTEX: OMEGA PENTA 30S and OMEGA DUO 30. Available in OMEGA 30S, OMEGA 30L, OMEGA 40S, and OMEGA 40L models, this Series is engineered to meet the demands of industries requiring complex machining and high-performance capabilities. The OMEGA Series is ideal for a variety of industries, including orthopedic implants, automotive, aerospace, medical devices, and electric vehicle (EV) components. From knee implants and hip joints to EV motor covers and steering rack housings, the OMEGA Series delivers superior results with precision and speed.

The new OMEGA Series is engineered to transform manufacturing operations, offering innovative features and unparalleled productivity for the most demanding machining challenges.

PHOMEX H

A state-of-the-art solution integrating Laser Wire Direct Energy Deposition (DED), Liquid Metal Jetting Technology, and CNC Machining into a single platform, this hybrid innovation is designed to meet the diverse demands of modern manufacturing industries like electronics, energy and medical industries, delivering unmatched versatility and efficiency. Laser Wire DED Technology ensures precise additive manufacturing for complex geometries, minimizing material wastage while cate-



Source: BFW

ring to high-performance industries like molding, aerospace, and automotive. Liquid Metal Jetting Technology enables rapid, layer-by-layer deposition of liquid metal droplets, producing components with exceptional surface quality and reduced lead times. Integrated CNC Machining provides in-situ post-processing for high-precision, dimensionally accurate parts with superior surface finishes.

ST 500X-2500 MTS

Developed in collaboration with Swedish Machine Tool (SMT), the ST500/2500 Mill Turn Machine redefines multi-tasking machining for industries like Aerospace, Defence, Energy, Oil & Gas, Shipbuilding, and Railways. The ST500/2500 combines turning, milling, and drilling in a single setup, reducing production time. Backed by SMT's Swedish precision and BFW's trusted engineering, the machine is tailored for complex parts like crankshafts, valve bodies, and aerospace components.

The ultimate solution for modern manufacturing needs, the Mill Turn Machine promises precision, power, and productivity.

WHN 130

Developed in collaboration with Tos Vandroff, the Horizontal Boring-Milling Machine WHN 130 from Bharat Fritz Werner Ltd (BFW) is designed for heavy-duty machining, offering unparalleled versatility and precision for industries like Aerospace, Defence, Oil & Gas, Shipbuilding, and Machine Tools. The machine is ideal for large-scale machining of complex parts such as turbine housings, ship components, and precision aerospace parts. The B-Axis rotation allows for exceptional flexibility, reducing setup time, and increasing productivity. Counterbalanced headstock ensures stability and accuracy, even with heavy materials. The WHN 130 merges cutting-edge engineering and precision to offer an unparalleled solution for the toughest machining challenges.



Source: BFW

Visit us at Hall 3A, Stall B111

High Speed High Precision CNC Rotary Tables

4th Axis redefined

- Integrated angle sensor
- Positioning accuracy: ±5"
- High clamping torque
- Universal mounting

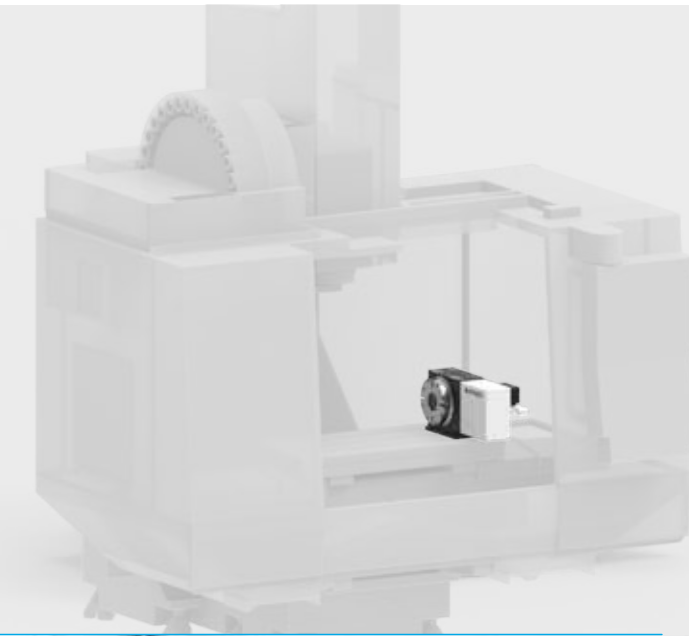
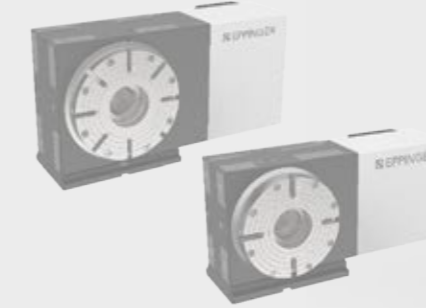

Your Partner For All Tool Holding Solutions

Up to fully automated tool change on lathes

- 1 QUICKLOCKBMT® tooling system
- 2 Tool holder HSK/SK/PSC
- 3 Automation for tool holder & work piece
- 4 Your work piece

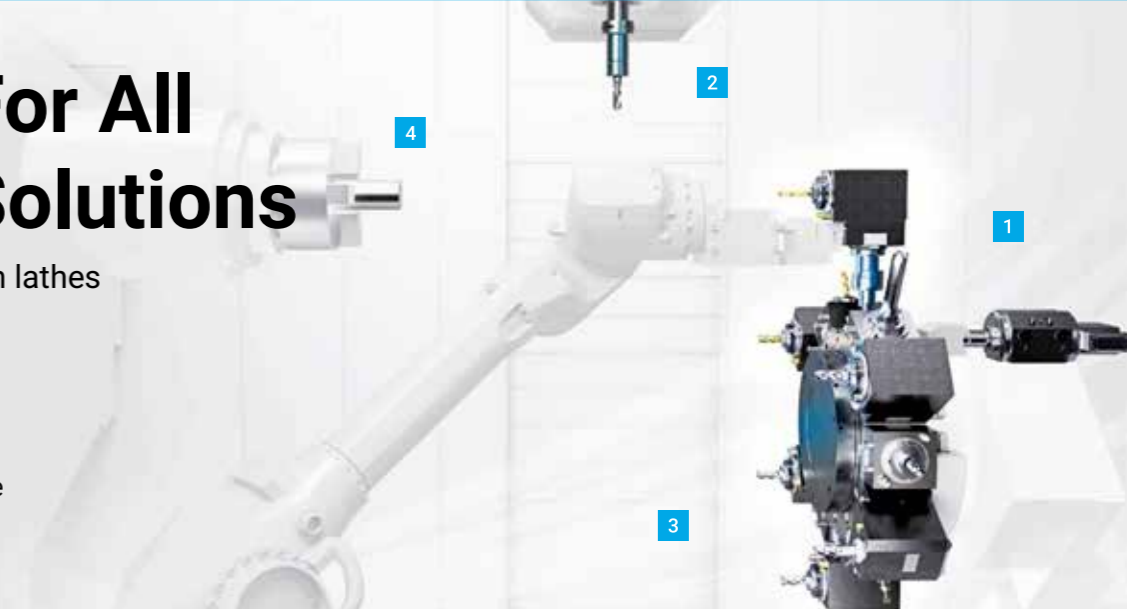

Precision Gear Units

For all machine tools

- 1 Tool disk / magazine
- 2 Tool changer
- 3 Material handling solutions

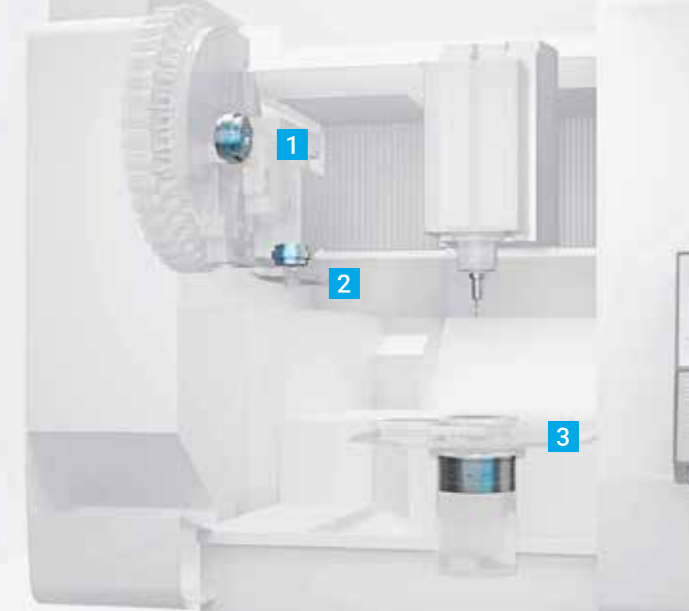

IMTMA INITIATIVE

i2 Academia Pavilion: A Platform to Learn and Evolve



i2 Academia Pavilion is an exclusive opportunity for Indian academic and R&D institutions to showcase their research and development capabilities in the metalworking sector.

i2 Academia Pavilion is a flagship initiative of Indian Machine Tool Manufacturers' Association (IMTMA) to promote collaboration between industries and academia, develop transformative new technologies, and understand each other's contexts and challenges through the platform of IMTEX, its renowned machine tool exhibition.

It is an exclusive opportunity for Indian academic and R&D institutions to showcase their research and development capabilities in the metalworking sector. Selected institutions get the chance to display up to four posters and conduct product demonstrations, with IMTMA providing the exhibition space free of charge.

In a momentous celebration at IMTEX 2025, the i2 Academia Pavilion witnessed the acknowledgment of outstanding students. Among 33 colleges and more than 50 projects, two prestigious awards were presented. The first prize, in the i2 Academia Pavilion Award category, worth ₹50,000, was awarded to KLS Gogte Institute of Technology, Belagavi. The second prize, worth ₹25,000, was

secured by Amrita Vishwa Vidyapeetham, Kollam. The third prize, worth ₹15,000, was won by SASTRA Deemed to be University, Thanjavur. In addition to these awards, the Popular Choice Award was also presented. The first prize in this category was won by Vishwakarma Institute of Technology, Pune, while SASTRA Deemed to be University, Thanjavur, secured the second prize. **SD**

JAGRUTI Concludes with Two Assignments for Participants



A skilled engineer must possess strong abilities to observe and quantify those observations effectively. On the second day of JAGRUTI, efforts were made to instill these critical skills among the 29 participating students, who were divided

into smaller groups. Each team was asked to present its observations from the previous day's stall visits. After each presentation, mentors provided feedback, highlighted missing aspects and guided students on how to improve their analytical approach.

JAGRUTI, an IMTMA initiative, is designed to nurture students to make them industry-ready. The program extends beyond the two-day event. To reinforce learning, IMTMA has assigned two tasks to the participants. The first assign-

ment, to be submitted by February 15, requires students to write a detailed report on their observations of IMTEX 2025. The second assignment, due by February 28, requires students to submit a project focused on metal manufacturing. **SD**



Indian Machine Tool Manufacturers' Association

Catalyzing Indian Manufacturing

IMTMA Membership Benefits

- Networking opportunities with key customer segments
- Special rates for participation in select events and training programmes
- Access to technical advisors and experts for business development
- Recognition through Awards

- Facilitation with institutions and agencies for technology development
- Access to publications and reports
- Access to export market opportunities through Buyer-Seller Meet / Delegation visits / Exhibition participation, etc.



Join our members' community

For details: +91 80 6624 6629
membership@imtma.in

www.imtma.in

METALWORKING FLUIDS

Writing the Next Chapter With Customers

At IMTEX 2025 & Tooltech 2025, Blaser Swisslube aims to highlight its high-performance, technology-driven, and sustainable offerings that enhance productivity, improve economic efficiency, and deliver superior machining quality. The team is eager to connect with its existing and potential customers in the Digital Manufacturing Hall.



customers can start to gain advantages of these tools. Interested customers can register themselves at the booth.

Insights from Blaser Technology Center: It is a unique aspect at Blaser Swisslube which helps customers a lot. Valuable insights from Blaser's Technology Center in Hasle-Rüegsau is being shared, offering further opportunities to engage with innovative solutions and advanced technologies.



Liquid Tool Analyzer helps in tailoring solutions for specific machining challenges: Blaser's simulation tool helps customers to bring transparency in their data points related to machining process and coolants. It brings all the data together. "This unique approach allows users to simulate various improvements and set goals for overall efficiency enhancements before starting the tests. This helps in optimizing processes and ensuring better outcomes before implementation," he adds. This approach has shown significant results, with customer tests demonstrating a 20-40 percent increase in tool life and an 8-15 percent boost

» By combining our expertise in metalworking fluids with the strengths of our partners, we provide integrated solutions that boost productivity, extend tool life, and optimize machining processes. At IMTEX 2025, we aim to highlight how these partnerships are shaping the future of manufacturing and helping our customers maintain a competitive edge in a constantly evolving industry. «

Punit Gupta
 Managing Director
 Blaser Swisslube Solutions Pvt Ltd

Blaser Swisslube Solutions is firmly committed to helping its customers become more productive through various digital initiatives, assures Punit Gupta, Managing Director, Blaser Swisslube Solutions Pvt Ltd. "With tools we have already developed, as well as those currently under development, we are looking towards the future, anticipating the challenges our customers face, and investing in solutions to address those challenges in advance," he shares.

challenging area to develop products especially suited for MQL," he adds.

Action at Blaser Booth

The company booth at IMTEX 2025 features a blend of technology and fun, offering an engaging experience for visitors, shares Gupta.

Smart Automation for smart factories: There are many digital initiatives at Blaser Swisslube which will help customers to be more productive. The company is initiating its journey of releasing these tools in India on a step by step approach basis. Custo-

Blaser Showcase at IMTEX 2025

Blaser has two key product groups to highlight: Water Miscible Coolants and Neat Oils. "We are introducing several innovative products, including B-Cool Motec 501, Synergy 915, Grindex S35, and Blasocut 201 under water miscible coolants category. Blaso-grind GTM 4, Blasomill 15, Blasomill GT22X are new neat oils," he shares. These products are specifically designed to enhance process stability and reliability adding to the overall superior machining performance. Minimum Quantity Lubrication (MQL) is another interesting area wherein significant work has been ongoing in evolving technology and creating solutions. "Many projects have been concluded successfully, where in we see vast improvements. When using MQL, the entire process must be taken into consideration. It is a



in productivity. "By emphasizing data-driven decision-making, transparency, and long-term partnerships, we help customers achieve improved performance and profitability in the evolving manufacturing environment," notes Gupta. Blaser Swisslube collaborates with several key industry partners, all united by a common goal: to enhance productivity and economic efficiency for its customers in a sustainable manner. "At IMTEX 2025, we aim to highlight how these partnerships are shaping the future of manufacturing and helping our customers maintain a competitive edge in a constantly evolving industry," says Gupta, summing up. **SD**

Blaser Swisslube Solutions Pvt Ltd
 www.blaser.com
 Hall & Stall: 7/A-110

MACHINE TOOL SOLUTIONS

Bringing Real and Virtual Worlds Together

As the only technology company with end-to-end solutions across the entire machine tool manufacturing value chain, Siemens Ltd, at IMTEX 2025 & Tooltech 2025, is showcasing integrated portfolio to connect the real world with the digital world. The company has introduced MACHINUM, its digitalization portfolio based on Siemens Xcelerator to enhance productivity and sustainability in the machine tools industry. "The MACHINUM portfolio manages, analyzes and optimizes machines and shopfloors. It enables IT-OT integration for industrial use cases like intelligent resource management, machining process

optimization and more," shares Vijay Pratap Singh, Head Motion Control, Digital Industries, Siemens Ltd. The company is also launching its latest 5th Gen SINUMERIK 828 and its Digital Twin that gets even more flexible and open. "Additionally, our high-performance, compatible, future-oriented SINUMERIK ONE and its Digital Twin ensure that our customers are perfectly equipped for the future," he reveals.

MACHINUM for Operational Efficiency and Productivity

MACHINUM is Siemens' CNC digitalization software portfolio

designed to help machine tool users and builders optimize shopfloor performance and productivity. "This digitalization portfolio is integrated into Siemens Xcelerator, allowing companies in the machine tool sector to better facilitate digital transformation – making it more efficient, faster and scalable in both manufacturing and design, and the demand for energy efficiency, sustainability and high-quality product manufacturing. The technology is not limited to SINUMERIK-controlled CNC machines, which allows the MACHINUM portfolio to be integrated into any existing manufacturing environment to future-proof the shopfloor," explains Singh. "As one of the technology players with integrated solutions across the entire value chain, one of our prime focus areas is to support the accelerated adoption of digitalization and support the industry in moving up the value chain through co-creation," he adds.



Source: Siemens Ltd

» We believe to build a future-proof machine tool industry. Our integrated technology offerings like the MACHINUM digitalization portfolio, new age SINUMERIK controllers, and others will help us achieve this growth in the coming years by accelerating their digital transformation.◀

Vijay Pratap Singh
Head Motion Control,
Digital Industries
Siemens Ltd

Siemens Ltd
www.siemens.co.in/imtex
Hall & Stall: 5/B-112



ADVANCING MANUFACTURING

Precision Rotary Tables for Future

Please visit us at **Stall No. A102, Hall No. H1A**

Experience with us **New Technologies & Innovations**

PMT MACHINES LIMITED

PUNE & HALOL

CNC Turning Center 5000 ABC

CNC Gear Hobbing

CNC Vertical Turning

CNC Cylindrical Grinding

CNC Internal Grinding

Surface Grinding

Automat

YOU ARE INVITED TO VISIT THE EXHIBITION
HALL NO - 2A STALL NO - B110

23-29 January, 2025 | BIEC - Bangalore

www.pmtmachines.com

Introducing Advanced Automation

New Launches

5th Axis Tilting Rotary Table

Direct Drive Tilting Rotary Table

Direct Drive Cantilever Table

Roller Cam RT

Direct Drive Production System

IOT Enhanced Rotary Tables

Scan this code or Log on to ucamind.com

Contact

080-40744712
info@ucamind.com
www.ucamind.com

Head Office

A-11/12, 1st Stage, 1st Cross,
Peenya Industrial Area,
Bangalore - 560058

HIGH-PRECISION MACHINES

Francis Klein Localizes Global Innovation



“IMTEX provides an ideal platform for us to meet customers from various OEMs and Tier-1 who are interested in high precision and productive machine tools,” Nikhil Agrawal, Managing Director, Francis Klein & Co Pvt Ltd. The company, in the ongoing IMTEX 2025, is exhibiting its latest developments, including fixturing, tooling, abrasives, stones, and services.

Future-Ready Machines on Display

The display includes a Stone Superfinishing Machine for lapping piston pins and bearing rollers; Gun Drilling Machines for drilling

main/counter shafts, fuel injection components; Vertical and Horizontal Honing Machines for auto components; and the latest R&D advancements to meet customer requirements of automotive specifications like BS VI Stage II Norms, CAFE, etc. “We will also be displaying our latest generation Gear Grinder along with Gear Inspection Machine to offer a ‘close loop solution’ to our gear manufacturers,” Agrawal shares.

Localization and Productivity

Francis Klein champions ‘Make in India’ by localizing German technology to make it cost-effective for

Indian manufacturers. “Our efforts ensure world-class machines are accessible to startups and SMEs, driving growth and job creation,” explains Agrawal. Machines from the company’s manufacturing plant Liebherr Machine Tools India, offer the latest generation controls with special software to increase productivity. “In our honing plant, we ensure that our fixturing concepts and material handling options, along with specialized tools and abrasives, help customers to attain New Gen honing.” The company’s Transfer Line Honing Machines incorporate in-process gauging, flushing, marking, scanning, post-gauging, oil drain, and many other features. “Further, the data can seamlessly be transferred from our machines to the customer PC for further analysis,” shares Agrawal.

Collab with Profiroll Technologies

Francis Klein’s partnership with Profiroll Technologies GmbH introduces high-precision Profile and Thread Rolling Machines and Spline Rolling machines to India. “Our machines feature electro mechanical drives with



» We have been focusing on bringing German machines to India with localization to make it cost-effective and affordable. Initiatives like ‘Make in India’ and PLI scheme have made these machines accessible to startups and mom-and-pop shops, empowering them to drive growth and create jobs.«

Nikhil Agrawal
Managing Director
Francis Klein & Co Pvt Ltd

thermally stable parts, low noise level, and high feed rate,” Agrawal remarks. “These machines built by us are working successfully and as the quality requirements further enhance, we see a strong possibility to deepen our customer outreach.”

Francis Klein & Co Pvt Ltd
www.francisklein.in
Hall & Stall: 4/A-117

SUSTAINABLE LUBRICANTS

Motul’s Bio-Sourced Machining Lubricants



The MOTUL GREEN TECH products are based on green sources of base oils and additives. They are label-free and HSSE compliant. The sustainable and

environment-friendly technology is oriented towards green machining products. The advantages of Motul’s bio-sourced machining lubricants are numerous. They are operator-

friendly and ensure a safe and clean shop floor environment. These lubricants offer high performance with low misting, excellent wettability, a high viscosity index (VI), and user-friendly application.

Additionally, they are biodegradable, allowing for easy disposal and reduced waste. They also contribute to improved health and safety standards. With MOTUL GREEN TECH™, the commitment is based on three fundamental pillars: develop environmentally-friendly products from renewable raw materials; provide performance to increase productivity and reduce chemical consumption; and reduce energy costs related to the use of the products. The green products on offer include soluble and neat metalworking fluids, cleaners, hydraulic and slideway oils, and greases.

Motultech India Pvt Ltd
www.motul.com
Hall & Stall: 4A/A-106

CENTRELESS GRINDERS

MGT’s Manual Centreless Grinder CLG 5025 FWR

The name ‘Micromatic’ is synonymous with ‘Precision Grinding’ in India since 1973. Micromatic Grinding Technologies is India’s largest CNC Grinding Machines manufacturer, catering to domestic and export markets worldwi-

de. MGT has been manufacturing a wide range of External, Internal, Universal and Special Purpose cylindrical grinders in CNC, PLC and Hydraulic versions.

at a surface speed of up to 45 m/s, powered by a 22 kW motor. Both the grinding and regulating wheel heads are designed with anti-friction spindle bearings to ensure maintenance-free operation. For enhanced rigidity, both wheel heads are mounted on V and flat guideways. Additionally, copying templates are available for both grinding and regulating wheel dressers. The machine also offers the possibility of integrating independent floor-mounted automation systems.

Centreless Grinder with Fixed Work Rest Blade Arrangement – CLG 5025 FWR

The Manual Centreless Grinder CLG 5025 features a fixed work rest blade with regulating and grinding wheels mounted on a moving slide. Typically, the machine is designed with applications involving long round bar grinding for through feed grinding. The machine accommodates long round bar components ranging from $\phi 3$ to $\phi 120$ mm, with a maximum length of 245 mm in plunge grinding. It supports a grinding wheel of up to $\phi 245$ mm, operating

Micromatic Grinding Technologies Pvt Ltd
www.micromaticgrinding.com
www.acemicromatic.net
Hall & Stall: 5/B-110



Source: Micromatic Grinding Technologies Pvt Ltd

GEAR TESTING SYSTEMS

Marpos’s NVH G-EAR at IMTEX 2025

At IMTEX 2025, Marpos is presenting one of its most valuable applications for gear measurement and testing: the NVH G-EAR machine. With the growing adoption of hybrid (HEV) and fully electric vehicles (EV), drivetrain noise has become a major challenge for car manufacturers. In battery electric vehicles (BEVs), a silent gearbox not only ensures the mechanical reliability and efficiency of the electric drive unit but also enhances driver comfort. For achieving a silent gearbox, it is paramount to test each individual gear 100 percent prior to the assembly of the transmission or gear redu-

cer. Identifying potential noisy gears at this stage results in significant time and cost savings for manufacturers. The ideal solution for gear noise testing in a manufacturing environment is the Marpos NVH G-EAR, a machine that is capable to test parts under challenging operating conditions (3000 rpm rotation speed, 40 Nm torque) using a special master gear that engages with the part based on the Single Flank rolling action.

Marpos India Pvt Ltd
www.marpos.com/eng/
Hall & Stall: 3A/B-102



Source: Marpos

Marpos NVH gear tester can detect macro-geometry and micro-geometry defects responsible for gear whine and noise phenomena.

FLUID PERFORMANCE MONITORING

Quaker Houghton Creates an Intelligent Future of Fluids

Quaker Houghton has developed a platform that specifically addresses challenges and allows manufacturers to benefit from optimizing fluids and processes. QH FLUID INTELLIGENCE™ provides real-time monitoring and control of fluid performance and cost, delivering fast, accurate, and actionable insights. Customizable, scalable, and easily integrated into manufacturing operations, it drives down waste, risk, and total cost of ownership. The platform combines four key elements: Quaker Houghton’s world-class fluids, application expertise, hardware, and software. Specific to hardware, the QH FLUIDMONITOR™ family of hardware uses proprietary sensor technologies for automatic real-time

measurement of key fluid and process parameters. This reduces manual sampling and analysis. The QH FLUIDCONTROL™ family of hardware integrates proprietary sensors and control equipment for automatic measurement and physical control of key fluid and process parameters. These hardware families work in tandem with the third element, QH FLUIDTREND™, an intuitive, user-friendly software for viewing the real-time and historical data and analytics from QH FLUIDMONITOR™ and QH FLUIDCONTROL™. QH FLUIDTREND™ offers manufacturers not just data, but insights on how to optimize fluids and processes. This improves predictability of outcomes, something prized by all manufacturers.



Quaker Houghton
www.quakerhoughton.com
Hall & Stall: 5/A-129

Source: Quaker Houghton

VISITOR SPEAK



Impressed with the Latest Machine Tools Displayed

“ This is our sixth or seventh time to IMTEX. Since we are into dies and molds manufacturing, our focus was on exploring the latest machining technologies for dies and molds. I was impressed with some of the latest machine tools that can help us in enhancing our production systems. It's encouraging to see Indian manufacturers actively participating in the exhibition and showcasing advanced machining technologies. Unlike my previous visits on the 3rd or 4th days, attending on the first day meant the crowd was lighter. This allowed us to thoroughly understand some of the machines. I hope more visitors take advantage of this versatile display of machine tools and benefit from the innovations on offer.

Rahul Akolkar
Proprietor
Akolkar Industries



IMTEX 2025, a Highly Organized Expo

Previously, I was part of the manufacturing industry, but now I'm in the service industry. However, I remain keen on staying updated with the latest developments in manufacturing, which is why I'm here. I've observed significant advancements in automated machine tools, which are truly impressive. These innovations will not only reduce cycle times but also enhance the accuracy of manufactured products. As for the organization of the exhibition, it has been excellent. IMTEX has successfully showcased almost every cutting-edge manufacturing technology under one roof. I will definitely attend the next IMTEX as well.

Sumanth NS
Senior Engineer, Power Systems
Bangalore International
Airport Ltd



Have Identified Relevant Indian Substitutes for Foreign Machines

I am here to explore the latest Indian substitutes for foreign machinery, which offer greater automation and reduced production time. I have identified a few highly advanced Indian machines at the exhibition. Our company's Deputy General Manager is here and together we will be selecting India-made machines to enhance our workshop's capabilities. IMTEX 2025 is one of the best-organized exhibitions I have attended.

Harikumar TK
Deputy General Manager
Vikram Sarabhai Space Centre, ISRO
Trivandrum

DELEGATE SPEAK



IMTEX's Popularity is Growing

I have been part of most IMTEX exhibitions. One of the advantages of the show is that it serves as a medium to gain insight into what is available in the contemporary market.

Many end users cannot fully grasp the features of machine tools just by going through advertisements or brochures. IMTEX provides a unique platform where those interested in the latest technologically advanced machine tools can experience them firsthand. The increase in the number of stalls at IMTEX 2025 reflects its growing popularity and impact.

Although the latest technologies are being incorporated into the latest machine tools, their impact will be limited unless they become affordable for MSMEs. There is no doubt that more technologies will continue to enter the machine tools industry. What is required is these advancements become cost-effective and hence accessible to smaller enterprises. Therefore, alongside technological advancements, we must also focus on making these machines more cost-effective.

Burzin J Wadia
Ex VP Innovation Tech & Engineering
Godrej Appliances



Source: Magic Wand Media

MILLING MACHINES

Redefining Precision and Reliability

GROB Machine Tools India views its participation in IMTEX 2025 as a key opportunity to demonstrate its technological prowess and strengthen its position in the global market. The event offers a platform for the company to showcase the capabilities and advancements of its state-of-the-art machines, which are designed to meet the growing demands of precision manufacturing across various industries. “In essence, IMTEX 2025 is not just a platform for GROB India to display its machines, but a strategic venue for reinforcing its brand as an innovative global player in the machine tools industry,” adds LJ Naidu, Managing Director, GROB Machine Tools India Pvt Ltd.

Raising the Bar in Manufacturing

GROB India showcases its Universal Five-Axis Milling Machine, Model G352, for precision and versatility in complex machining applications. It integrates five-axis simultaneous machining, enabling the production of intricate components with superior accuracy and surface finish in a single setup. “With its ability to handle a wide range of materials, including tough alloys and composites, the G352 is ideal for industries like aerospace, automotive, and energy,” asserts Naidu.

GROB's India-Made Machines

A major highlight is the announcement of GROB's India-made machines, set to launch by late 2025 or early 2026. These machines aim to meet the growing demand for high-quality, cost-effective manufacturing solutions tailored to the Indian market. By leveraging local production capabilities, shares Naidu, GROB aims to offer machines that combine advanced technology with localized features, making them more accessible and affordable for Indian manufacturers.

Maintaining Global Standards Locally

GROB's sixth global production plant in India reflects its commitment to localizing production and supporting India's goal of becoming a global manufacturing hub. The facility offers customized solutions, faster delivery, and enhanced after-sales support. “Producing machines in India allows us to meet local manufacturers' needs while leveraging lower costs, operational flexibility, and skilled labor,” says Naidu. “By integrating local manufacturing with our global quality standards, we deliver cost-efficient, customized solutions without compromising the precision and reliability that define our brand.” SD

GROB Machine Tools India Pvt Ltd
www.grobgroup.com
Hall & Stall: 4/C-116



UNLOCK PRECISION IN ELECTRONICS MANUFACTURING WITH ANCA CNC MACHINES



Download a free whitepaper on the latest trends, opportunities, and strategies shaping India's thriving electronics sector



Visit us at IMTEX 2025
Hall 4, Stand B110

PRECISION MACHINE TOOLS

Focussed On Precision and Productivity

“IMTEX has always been a strategic platform for us to showcase our latest innovations and connect with a global audience,” said T Venkatesan, Vice President, S&T Machinery Pvt Ltd. S&T Machinery is presenting an extensive lineup of 18 advanced machines that exemplify the company’s focus on precision, reliability, and productivity.

Innovative Machines on Display

“At IMTEX 2025, we are showcasing STM brand machines, which

are crafted in Taiwan and manufactured in India,” shared Venkatesan. These include a 5-axis Machining Center, Horizontal Machining Centers, Double-Column Machining Centers, Drill Tap Centers, and Cylindrical Grinding Machines.

“Our lineup also includes Vertical Machining Centers (VMC) from YCM and large CNC Wirecut EDM Machines from Excetek Technologies Co Ltd. These are high-precision, reliable solutions,” he added. In addition, S&T is also exhibiting solutions from the Indian brand

SKITEK, such as deep-hole drilling machines, long-travel VMCs, the STM Laser Welding Machine, and the SPREX Die Spotting Machine. These offerings are “designed to meet diverse manufacturing challenges with advanced technology,” explained Venkatesan.

Exciting Launches and Live Demonstrations

“We are unveiling revolutionary machines, including the FX400 5-Axis Machining Center, Vertical Machining Center VL1570, ST3060 surface grinder, and Rotary 800 grinder,” said Venkatesan.

Other highlights include Excetek Technologies Co Ltd’s flagship High-Precision CNC Wire EDM Machine NP1280 and SKITEK’s SN400C Die Sinking EDM Machine, featuring a column-move design. Visitors can experience live demonstrations of these innovations, view machined job samples, and engage with experts for tailored solutions. “This will be an immersive experience for everyone visiting our stall,” Venkatesan noted.



Source: S&T Machinery Pvt Ltd

“IMTEX has always been a strategic platform for us to showcase our latest innovations and connect with a global audience.”

T Venkatesan
Vice President
S&T Machinery Pvt Ltd

Partnerships and Vision

“Our partnerships with YCM, Excetek, and SKITEK are pivotal in delivering world-class technologies to our customers,” remarked Venkatesan. He emphasized that these collaborations have enabled S&T to meet evolving market demands effectively. **SD**

S&T Machinery Pvt Ltd
www.stmcnc.com
Hall & Stall: 1A/B-101



Source: Magic Wand Media

Forming the Future of Manufacturing



International Forming Technology Exhibition

Concurrent Shows



Asia’s Largest Exhibition on Metal Forming and Manufacturing Technologies

21 – 25 January 2026 : BIEC, Bengaluru



Venue



AUTOMATED TURNING SOLUTIONS

Enhancing Precision and Productivity



Source: Magic Wand Media

“IMTEX 2025 is a key platform for us to showcase our innovative solutions and connect with industry leaders,” says Rishi Kapoor, Associate Vice President – Sales, Meiban Engineering Technologies Pvt Ltd. The company is displaying four advanced machines tailored to enhance precision and productivity across industries.

Revolutionary Machines on Display

- **MW120EX:** This flagship model excels in high-precision parts and shorter cycle times. It features one of the fastest gantry loaders and integrates with a

Post Process Gauge for online inspection and auto-correction.

- **MW80HGT:** A compact twin-spindle turning machine with gang tooling and twin gantries, designed for the shortest cycle times. Its robust built ensures accuracy, making it ideal for hard part turning.
- **MT100/T3:** A multi-tasking powerhouse featuring three turrets, each with 3-axis movement (X, Y, Z). It supports up to 45 live tools and is compatible with bar feeders and chucking components.
- **Twin Spindle Turn-Mill Center:** Making its debut at IMTEX

2025, this machine offers unmatched efficiency for batch and high-volume production, standing out in the industry.

Industry Focus and Versatility

“Our MW Series is particularly popular in the Indian Automotive industry,” Kapoor notes. While the Automotive sector is a primary focus, Meiban also caters to industries such as Oil & Gas, Hydraulics, Medical, Construction, Off-Road Vehicles, Precision Engineering, and Pumps & Valves.

Automation at its Finest

With turnkey solutions inspired by its parent company Murata Machinery Ltd, Meiban Engineering Technologies ensures 24x7 production with minimal downtime. “We maintain a stock of around 10 machines at all times, tooled locally by our team to meet customer demands,” Kapoor adds.

Customized automation solutions, CNC Servo Turret Punch Presses, and high-end twin-spindle chuckers provide maximum efficiency with remote online support, ensuring minimal breakdowns and high uptime. Kapoor emphasizes,



Source: Meiban Engineering Technologies Pvt Ltd

“We keep innovating our products regularly to meet end-user demands. Our automation and turnkey solutions are customized for each customer, ensuring 24x7 production with minimal breakdowns. At IMTEX 2025, our latest technologies, such as the Twin Spindle Turn-Mill Center, reflect our dedication to precision and productivity.”

Rishi Kapoor
Associate Vice President – Sales
Meiban Engineering Technologies Pvt Ltd

“Our multi-tasking machines cater to batch production, from low to high volumes, delivering consistent performance.” **SD**

Meiban Engineering Technologies Pvt Ltd
www.meibanengg.com
Hall & Stall: 5/B-105

AQUEOUS-BASED CLEANING SYSTEMS

Ecoclean India Launches EcoCvertex at IMTEX 2025

Ecoclean India has unveiled its latest innovation, EcoCvertex, at IMTEX 2025.

EcoCvertex is a cutting-edge aqueous-based cleaning system, engineered for industries demanding top-tier cleaning performance. With its compact design, advanced features, and future-ready technologies, EcoCvertex becomes a standout solution for modern manufacturing environments.

EcoCvertex is a cutting-edge aqueous-based cleaning system, engineered for industries demanding top-tier cleaning performance. With its compact design, advanced features, and future-ready technologies, EcoCvertex becomes a standout solution for modern manufacturing environments.

The EcoCvertex is ideal for achieving stringent cleanliness standards while optimizing operational efficiency. With a modern yet compact design, superior cleaning performance, cost and energy efficient, and future-ready integrations, this machine elevates cleanliness standards and maximizes operational efficiency. Equipped with the latest PLC controls and an interactive HMI, the EcoCvertex offers precise process customization and real-time monitoring, making this machine both user-friendly and highly efficient.

Key Features

- **Versatile Cleaning:** The machine combines spray cleaning, injection flood washing, ultrasonic cleaning, and efficient drying methods like vacuum and hot air drying.
- **Compact Design:** Its space-efficient footprint facilitates easy maintenance.
- **Customizable Load Sizes:** It accommodates 770 x 480 x 300 mm or 670 x 480 x 400 mm, ensuring flexibility.
- **Effective Dual Filtration:** The system enables dual filtration for improved fluid management and superior filtration efficiency with High Performance Filter Element (HPFE). **SD**

Source: Ecoclean Machines Pvt Ltd

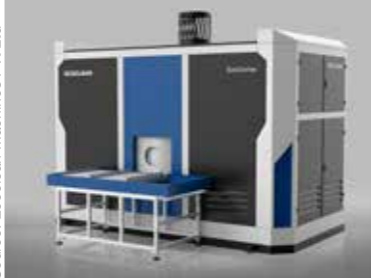

Ecoclean Machines Pvt Ltd
www.ecoclean-india.com
Hall & Stall: 4A/C-118

VERTICAL MACHINING CENTERS

JU 40 – LMW’s 5-axis Vertical Machining Center

The JU 40, 5-axis Vertical Machining Center from LMW Ltd is built for high-speed operations with a stroke of 400 mm x 550 mm x 550 mm and a table size of Ø500 mm, accommodating workpieces up to 500 mm x 400 mm. It features a BBT 40 spindle taper with a speed of 15,000 rpm and a rapid traverse rate of 48 m/min. This machine is suitable for industries including Aerospace, Medical, Energy, Automobile, Defence, and General Engineering. **SD**



LMW Ltd | www.lmwnc.com
Hall & Stall: 5/A-108

Source: LMW Ltd

CAM SOLUTIONS

Powering Precision with CAM Technology



“We have always looked at IMTEX as a pivotal platform to demonstrate our advanced CAM solutions to a diverse audience, ranging from large-scale enterprises to MSMEs,” says Vineet Seth, Managing Director – South Asia & Middle East, Mastercam APAC. The company’s showcase centers on its current release of Mastercam 2025, with a spotlight on new features

designed to enhance efficiency and precision, including Mastercam Deburr, that automates the removal of sharp edges and burrs, reducing manual intervention and improving part quality.

Revolutionary Upgrades in Operations

Mastercam 2025 introduces several significant enhancements to

3-axis and 5-axis milling, including optimized toolpath control, improved surface quality, and enhanced material removal rates. New features for rest roughing, advanced collision detection and avoidance, and real-time simulation are notable mentions. Seth emphasizes, “These updates empower manufacturers to achieve superior finishes and shorter cycle times, making their processes more competitive and cost-effective.”

Dynamic Motion: The Game Changer

Over the years, Dynamic Motion Technology has evolved into one of Mastercam’s most transformative features. The top five impacts on machining efficiency encompass: Reduced cycle times, Extended tool life through optimized cutting forces, Enhanced machine longevity owing to reduced spindle stress, Improved energy efficiency, and Superior part accuracy and finish quality. These advancements allow manufacturers to maximize productivity while maintaining precision, reinforcing

Mastercam’s position as a leader in CAM innovation.

Strategic Vision for Growth

Looking ahead, Mastercam’s strategic vision for the next five years is focused on sustainable double-digit growth, with an emphasis on the aerospace, medical, and defence sectors that are witnessing substantial expansion. Participation in IMTEX 2025 aligns with this vision by enabling the company to connect with key stakeholders and showcase solutions tailored to these industries. “We will continue investing in skill development initiatives and strengthen collaborations with industry partners to provide integrated solutions, which remains a priority,” sums up Seth. “IMTEX serves as an ideal platform to forge such alliances, reinforcing our leadership in India’s manufacturing sector.” **SD**

Mastercam
www.mastercamapac.com
Hall Stall: 1B/A-102

EMPOWERING PROGRESS THROUGH AUTOMATION

8th Edition



SYMPOSIUM ON
AUTOMATION & ROBOTICS
EXHIBITION & CONFERENCE

June 2025, Pune

Meet the leading automation and robotics suppliers and solution providers

Promote your brand and consolidate your industry positioning

Network and engage with eminent speakers

Witness enriching presentations

Book Today

Prabhugoud Patil :
+91 9980432663 prabhu@imtma.in
or
Abhishek:
+91 9844294387, abhishek@imtma.in



Organized by
Indian Machine Tool Manufacturers Association

ABRASIVE SECTIONING MACHINES

Chennai Metco’s High-Capacity Oscillation Cutting Machines

Abrasive cutting is the optimal solution for high-speed sectioning of most metallic components, particularly hardened ones. It is also employed for sectioning components post heat treatment for quality check.

Large sections of hard components are particularly tough to be sectioned with abrasive sectioning and they pose a challenge. Implementing pulsed cutting and oscillation enhances the efficiency of abrasive sectioning.

Chennai Metco offers a wide range of abrasive sectioning machines for many various applications, including cutting heat-treated components, hard rods, carbide profiles, stones, refractories, etc. Chennai Metco application laboratory is ready to assist in identifying the most economical sectioning solution for hard rods, rails, ball screws, carbide rods etc. **SD**



Chennai Metco Pvt Ltd
www.chennaimetco.com
Hall & Stall: 1/A-101

Source: Chennai Metco Pvt Ltd

WIRE-CUT EDM, DIE SINKER EDM

Strengthening Indo-Taiwan Ties



Source: Magic Wand Media

Ching Hung Machinery & Electric Co., Ltd (Brand: CHMER) has been participating in IMTEX since 2004 when it would happen in Mumbai. Over time, it has established a relationship of mutual learning and growth with Indian users. “Our longstanding association with the Indian manufacturing industry has provided us the opportunity to closely witness its commendable growth. This year, we have strengthened our commitment to our Indian clients in the aerospace industry,

providing them with our solutions. We see immense potential in Indian manufacturing players and are highly optimistic of their growth,” shares Sephiroth Chao, Regional Sales Manager, Ching Hung Machinery & Electric Co., Ltd (Brand: CHMER).

Innovations Displayed at IMTEX 2025

The UA432L Green and Compact Linear Motor Drive Wire Cut EDM seamlessly integrates modularity, high efficiency, and advanced ener-

gy-saving features. It has been recognized with the prestigious ISO 14955 EU certification and Golden Energy-Saving Mark by TMBA.

Features

- **Compact Design:** The machine’s footprint is 20 percent less as compared to traditional models
- **High-Efficiency Energy Management System (HEMS):** Integrated power-saving and water-saving systems reduce total processing energy consumption by 40 percent.
- **In-House UX1 Linear Motor:** This ensures frictionless operation, reduced maintenance costs, higher accuracy and lifetime.
- **Next-Generation GenOS System:** The new GenOS plus Ether CAT transmission, based on Linux, offers computing performance 10 times faster.
- **CE Conformity:** EMC Cover and Automatic Sliding Tank door to match Automation production line by a robot.

Ching Hung Machinery & Electric Co., Ltd
(Brand: CHMER)
https://www.chmer.com/en
Hall & Stall: 1B/ A124

» Our long-standing association with the Indian manufacturing industry has provided us the opportunity to closely witness its commendable growth. This year, we have strengthened our commitment to our Indian clients in the aerospace industry, providing them with our solutions. **«**

Sephiroth Chao
Regional Sales Manager
Ching Hung Machinery & Electric Co., Ltd (Brand: CHMER)

Exploring Unique Partnership Models

As Indo-Taiwan technological cooperation gains momentum, CHMER is exploring unique partnership models and knowledge-sharing initiatives to deepen its engagement with Indian manufacturing enterprises. **SD**

IMTMA INITIATIVE

Engagement with Overseas Buyers @ IMTEX 2025



Source: Magic Wand Media

With the aim to facilitate export opportunities for Indian machine tool manufacturers, IMTMA, along with EEPC India, organized the ‘Engagement with Overseas Buyers’ on January 25 – 26, 2025, during the ongoing IMTEX 2025 at BIEC. The event served as a significant opportunity for IMTEX exhibitors to connect, learn new concepts, explore opportunities, and penetrate the overseas markets. The event received an overwhelming response from the machine

tool importers from the countries including Russia, Sri Lanka, UAE, and Vietnam.

Participants’ Take

Commending IMTMA for taking this initiative, Susantha Premalal, CEO & Managing Director, Pubudu Engineering Pvt Ltd, Sri Lanka, said, “I am delighted to witness the high-tech machinery on display. This exhibition truly highlights the remarkable growth of the Indian machine tools industry. Being from India’s neighboring country, this is a

great opportunity for us to explore a wide range of machine tools under one roof.” Sharing his experience, Rajeeva Madhyastha, TAT Corporation, Vietnam, said, “Our company specializes in trading machine tools, and we have been importing machines from Korea, Taiwan, China, and Europe, offering both sales and servicing. Our primary objective at this trade fair is to identify machine tools that can serve as cost-effective and high-quality alternatives to Chinese and Taiwanese machines. We are

already in contact with several Indian machine tool manufacturers, including ACE, BFW, Jyoti, Cosmos, and LMW.” Highlighting his reasons for attending, Vitali Kozin from Baltic Machine Tools, Russia, explained, “Sanctions imposed by the USA and European countries have impacted our market, prompting us to explore the Indian machine tool industry. We are looking to source heavy machinery from India and have already shortlisted several manufacturers. My next step is to follow up, negotiate, and finalize deals. This event has provided valuable contacts, and I am extremely pleased with the opportunities available here.” ‘Engagement with Overseas Buyers’, a buyer-seller meet at IMTEX 2025 has reinforced India’s position as a reliable and competitive machine tool hub, drawing strong interest from international buyers and paving the way for future collaborations. **SD**

Source: Jyoti CNC Automation Ltd



Jyoti CNC Automation Ltd
www.jyoti.co.in
Hall & Stall: 5/A-122

MULTI-TASKING MACHINES

Jyoti CNC's MTX Series for Unmanned Machining

Introducing the incredible MTX Series from Jyoti, crafted to meet the unique challenges of complex components that require precise 5-axis milling combined with 4-axis turn mill operations. This innovative series seamlessly integrates advanced 5-axis milling and 4-axis turn-mill capabilities, perfect for the intri-

cate world of single-piece component manufacturing.

With its outstanding precision, remarkable versatility, and top-notch efficiency, the MTX Series is a go-to solution for industries that demand peak performance and unwavering reliability. This state-of-the-art machine has multi-

tasking capabilities. It boasts a main electro-spindle featuring a C-axis and a secondary electro-spindle equipped with a Z3-axis for turning. It also includes a milling spindle with X1/Y/Z1 along with a B-axis, complemented by a live tool turret (X2/Z2-axis). In addition, it's outfitted with a high-capacity Automatic Tool Changer

(ATC) to keep one's production running smoothly. Engineered for high-precision, unmanned machining, the MTX Series is a game-changer in industries such as aerospace, automotive, mechanical, power, and oil & gas. It delivers exceptional tolerance and reliability even in the most challenging applications. **SD**

TWIN-SPINDLE TURNING MACHINES

Twin Spindle Twin Gantry CNC Chucker MW80HGT

Meiban Engineering Technologies Pvt Ltd
www.meibanengg.com
Hall & Stall: 5/B-105



Muratec Machinery, Ltd (Muratec)'s MW80HGT is a compact twin-spindle turning machine featuring a gang tooling (linear) concept. The machine offers high precision with a direct spindle drive construction and is ideal for hard part turning with short cycle times. This small yet powerful machine comes equipped with a 6" chuck and can accommodate up to four gang tools.

The MW80HGT has a spindle power of 7.5 kW and can achieve speeds of up to 6,000 RPM. It is capable of turning parts with diameters up to 80 mm and lengths of up to 50 mm.

Linear tooling eliminates turret indexing time, significantly reducing cycle times. Both swivel and horizontal-type loaders are available.

With a standard loading/unloading time as low as 2.9 seconds, the MW80HGT is an optimal solution for high-speed turning and simple parts such as small bearings, rings, gears, and hard part turning. Common applications include bearing outer and inner rings, differential pinion and side gears, compressor wheels, and more. The machine can be supplied with either single or twin gantry loaders.

Muratec is a global leader in providing fully integrated, built-in automation solutions for a wide range of applications. **SD**

PCD MILLING PROGRAMME FOR ALUMINUM MACHINING

Horn's PCD Milling Programme for Aluminum Machining



Source: HORN/NINCEA

The Horn high-performance PCD grade consists of a sophisticated mixture of diamond grains of different sizes.

With over 30 years of experience in the development and production of precision tools made from ultra-hard cutting materials, Horn offers a comprehensive range of PCD milling cutters for productive machining of aluminum. During this time, Horn has proven itself in numerous industries - and has thus become an important partner in the field of PCD tools.

The new PCD milling programme is part of this long-standing development and complements the portfolio. Based on market experience and customer requirements, Horn has methodically developed a complete standard programme of milling tools. The standard series range DM20 to DM90 enables reliable machining of aluminum, non-ferrous metals and technical plastics. With a focus on resource conservation, customized cutting-edge lengths and tool design, the tools are available from stock. With this product programme, Horn offers a wide range of standard and special tools, from simple PCD end mills to complex and modular combination tools. As a driving force, the focus is on economical, well thought out solutions with high productivity combined with Horn technology, flexibility, and reliability. The Horn high-performance PCD grade consists of a sophisticated mixture of diamond grains of different sizes.

As the volume percentage of diamond increases, so do the effective hardness, toughness, and cutting-edge quality. Strict quality standards and their control are a matter of course and ensure strong performance.

Machining of Aluminum

The tensile strength, elongation, hardness, and yield strength of aluminum can be influenced by alloying elements such as silicon,

magnesium, copper, zinc, and manganese. The material can become soft during machining due to heat development, stick to the cutting tool, and even destroy it due to disrupted chip flow. It is therefore important that the material and cutting parameters are properly matched. It depends on the aluminum alloy, the cutting tool, the cutting feed rate and speed, as well as the type and quantity of coolant.

Aluminum is a versatile material that is used in all sectors of the economy. Supplemented by the new PCD milling programme, Horn offers a broad portfolio of optimized tools for economical machining of the light metal.

Horn Tools for Machining Aluminum

The most important features of Horn's wide range of standard and special tools are special chip breaking geometries with sharp inserts, polished rake faces and coatings with very good anti-friction properties to counter the strong adhesion tendency of aluminum. Carbide inserts for grooving are ground peripherally to ensure extremely sharp inserts. For machining aluminum alloys with a high silicon content, the inserts are coated. The portfolio includes coated and uncoated circular tools and solid carbide cutters for milling. Single-edged milling cutters with a large chip space are also available for rapid metal removal rate based on high cutting data. Ultra hard cutting materials such as PCD and CVD-D with precision-lasered cutting edges are available for long service life or more complex work. MCD-tipped tools are used for high-polish machining of reflective surfaces or aluminum blow molds, for example. **SD**



Paul Horn GmbH
www.horn-group.com
Hall & Stall: 2B/A-114

Source: HORN/NINCEA

With the new PCD milling programme, Horn offers a wide range of standard and special tools, from simple PCD end mills to complex and modular combination tools.

UPSKILLING THE INDUSTRY

Making Students Industry-Ready

In its ongoing pursuit of excellence, the AceMicromatic Group (AMG) strongly believes that the industry has a major role to play in bridging the gap between the academia and industry. It is doing its bit to take India one step ahead in the journey of manufacturing excellence through its 'LEARN, PRACTICE & MASTER' program. AMG offers specialized courses and simulator-based training programs designed to equip individuals with the skills needed to excel in CNC programming. Its training modules are crafted by industry experts, ensuring participants gain hands-on experience and in-depth knowledge of the latest CNC technologies. Through these courses, the Group aims to bridge the skill gap in the manufacturing sector, empowering professionals with the expertise required to operate and program CNC machines efficiently. Its commitment to education and skill development underscores its dedication to advancing the capabilities of the manufacturing workforce.

CNC Simulator – Empowering Skills and Ensuring Safety

The CNC Simulator - Machine & Desktop versions are essential tools for education institutes and the industry. For schools and training centers, these simulators offer a safe, hands-on way for students, operators, and enthusiastic machinists to learn CNC programming and machine operations without the risk of damaging expensive equipment. This practical experience helps prepare them for real-world jobs. In the professional world, the CNC Simulator is a valuable asset. It

allows companies to create and test CNC programs before using real machines, which reduces mistakes, saves time, and uses resources more efficiently. Features like error detection and collision avoidance make sure programs are safe and effective, boosting productivity. The CNC Simulator is also cost-effective. It cuts down on material waste and machine wear and tear, leading to significant savings. For research and development, it provides a virtual space to try out new machining processes without incurring high costs and, thus, encouraging innovation.

AMG's Spotlight on Upskilling at IMTEX 2025

At IMTEX 2025, AMG is showcasing the Simulator, both the Desktop version as well as the Training Machine, with versatile features for upskilling CNC programming targeting engineering, diploma, and ITI students.

Overall, the CNC Simulator - Machine and Desktop versions enhance learning, improve efficiency, and promote innovation in CNC machining. Their realistic simulations, easy-to-use interfaces, and advanced features make them valuable tools for education institutes and the industry alike.

Stellar Series – STLR 120

The STLR 120 is a compact and efficient Metal 3D Printer designed for R&D, academic, and training purposes. Engineered for simplicity and performance, the STLR 120 operates

on a single-phase power supply with low power consumption. Its small footprint ensures seamless integration into labs or training centers.

With a build volume of Ø120 mm x 200 mm in height and powered by a 400 W laser, the STLR 120 delivers precision and reliability for high-quality metal parts. It features an open platform with customizable parameters, enabling extensive experimentation and fostering innovation in additive manufacturing. With its high-speed Galvano meters and small laser spot diameter, the machine ensures excellent resolution and superior performance.

The STLR 120 requires less than 1 kg of powder to start printing, making it highly economical for small-scale applications. Compatible with a wide range of validated materials, it supports diverse research needs, including the production of small medical implants, intricate components for different industrial applications. This versatility, combined with its focus on skill development and training, makes the STLR 120 a powerful tool for academic institutions, R&D facilities, and the medical industry striving to lead in the additive manufacturing revolution.



Ed-Mill by AMS

ED-MILL by AMS (AMS - Ace Designers Machining Center Division) is the next-generation Desktop Milling machine, designed for enhancing future generation skills. It is an ingeniously designed smallest machining center from AMS. ED-MILL is ideal for training and development initiatives in corporate training centers and technical education

institutions. It is a portable yet powerful machine suitable for machining non-metals like wood and nylon, and metals like brass and aluminium.

The machine is equipped with a Syntec CNC Control system and features X, Y, and Z-axis travels of 160 mm, 260 mm, and 80 mm, respectively. The table measures 460 mm by 270 mm, supporting a maximum load of 10 kg. The spindle delivers 0.8 kW of power, reaching speeds up to 15,000 rpm.



Source: Micromatic Machine Tools

Ed-Turn by Ace Designers

The Ed-Turn is a compact and light desktop CNC lathe designed to cater to the needs of educational institutions, training centers, and small-scale industrial operations. It is an ideal tool for teaching CNC programming, operation, and machining basics. Capable of cutting plastics, metals, machinable wax, and wood, this lathe supports operations such as ID/OD turning, threading, drilling, grooving, and taper threading. It can also be used for prototyping and small-scale manufacturing. Vocational training centers can also use it for skill development.

Key Features

- Versatile machining capabilities for a wide range of materials;
- Compact and portable design ideal for desktop or tabletop use;
- Robust construction with precision linear motion guideways for accuracy;
- User-friendly Syntec CNC control system for seamless operation.

The machine is designed to accommodate components of maximum Dia 60 mm and up to 200 mm in length. It comes with a flat nose spindle with 1.5 / 2.0 HP spindle motor power, achieving 3000 rpm maximum spindle speed. **SD**



Source: Micromatic Machine Tools



Experience the Value in our Machines & Solutions

Hall - 5, Stall - A 108



JHF 400 HIGH SPEED Horizontal Machining Center

- Stroke: (X,Y,Z) - 600 mm x 500 mm x 500 mm
- Automatic pallet changer
- Pallet Size - 400 x 400 mm
- High speed Spindle - 12000 rpm
- Twin Arm type ATC
- No. of Tools - 30 Nos
- Rapid Traverse Rate - 48 m/min



JH 550 HEAVY DUTY Horizontal Machining Center

- Stroke: (X,Y,Z) - 800 mm x 800 mm x 850 mm
- Automatic pallet changer
- Pallet Size - 500 x 630 mm
- Max. Spindle speed - 6000 rpm
- Spindle taper - BBT 50
- No. of Tools - 60 Nos
- Rapid Traverse Rate - 48 m/min



**PROPELLING TECHNOLOGY.
PROSPERING LIFE.**



POWER



jyoti.co.in/huron.fr

DEMONSTRATING **LIVE**

Hall **5**
at Jyoti Pavilion

Widest Range of CNC Machines

- | Turning / Turn-Mill Centers
- | Vertical Machining Centers
- | Horizontal Machining Centers
- | 5-Axis Machining Centers
- | Multi-Tasking Machining Centers

